

SPRO[®]

SPNPRQ20/0922R-4-A

2 Megapixel 4 in 1 IR Bullet Camera
Number Plate Recognition Camera



Key Features:

- 2 Megapixel progressive CMOS
- 1/2.9" 2.1 Mega-pixel Sony CMOS
- Max 25fps@2MP video output
- 4 IN 1 (CVI / TVI / AHD / ANALOGUE)
- 9-22mm Auto IRIS Motorized Lens
- Max IR LEDs Length 20m
- Defog, DWDR,3DNR,DSS,UTC
- IP66
- DC12V



SPECIFICATIONS

Model Number	SPNPRQ20/0922R-4-A
Image Sensor	2 Megapixel progressive scan CMOS
Effective Pixels	1920(H) x 1080(V)
Scanning System	Progressive
Electronic Shutter Speed	NTSC:1/60-1/100,000S PAL:1/50-1/100,000S
Min. Illumination	0Lux(30PCs SMD LEDs ON)
Max. IR LEDs Length	20m
IP Rating	IP66
Viewing Angle	Horizontal: 32°- 14°

(continued)

(continued)

Vertical Frequency	NTSC:60Hz PAL:50Hz
S/N Ratio	≥52dB
Lens	9-22mm Auto IRIS Motorized Lens
White Balance	ATW
OSD	YES
BackLight Compensation	AUTO
AUTO Gain Control	ON
Defog	OFF/ON
DNR	OFF/ON
WDR	OFF/ON
Video Out	CVI/TVI/AHD/ANALOGUE
Day&Night	AUTO/Color/BW/Ext
Gamma	0.45
Video Output	4 in 1 (AHD/TVI / CVI / CVBS)
Power Supply	DC12V±10%
Current consumption	550mA (MAX)
Dimension	231×84×110mm (9.1"×3.3"×4.3')
Weight	720g (25.4oz)
Storage Temperature	-30~+60°C
Operating Temperature	-30~+40°C

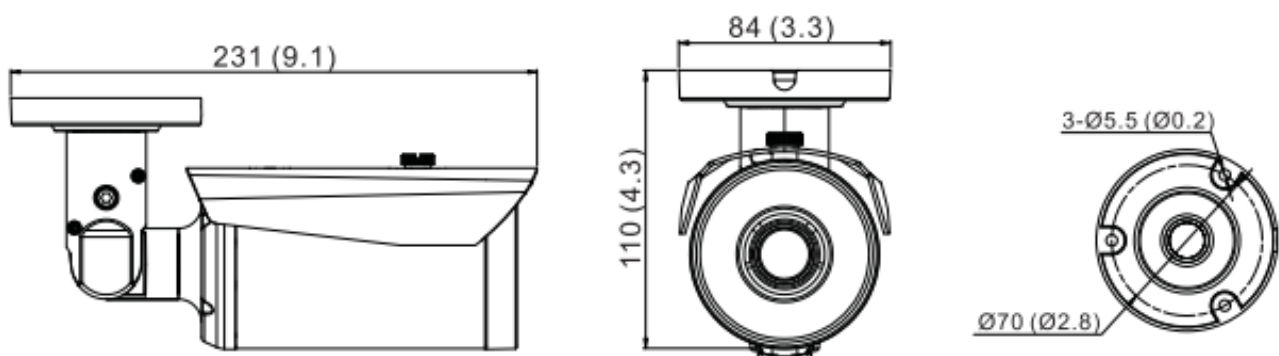

All specifications are subject to change without notice. Copyright © Luxrite Ltd. All rights reserved