

SPRO[®]

VI-PNLO1-2-BKT-F

Flush Mounted Box for 2 Modules



Key Features:

- Material: SPCC
- Size: 255.4mm*143.4mm*50.8mm
- Weight: 0.7kg
- Flush Mounted Box

INSTALLATION

- Mount case on wall. Fix with screws (ST3×18 cross recessed countersunk head tail tapping screws) to ensure the case cannot be removed.
- Align the holes on the front panel with the modules. Fix with screws (M3×6 cross recessed countersunk flat tail machine screw) to ensure the modules are attached to the front panel.
- Fix the front panel onto the case according to hole position. Fix with screws (M4×40 inner hex flower sunk head flat tail machine screw) to ensure the front panel is attached to the case.
- Write room no. or name of resident on provided name card . Insert name card cover.

NOTE

- Name card and name card cover are included in accessories by default.
- The modular system has two packages, 2 modules or 3 modules. The diagram shows 2 modules as an example.
- The device will only power up once all the modules are connected properly. Failure to connect all modules properly will result in a lack of power to all or some of the modules.

(continued)

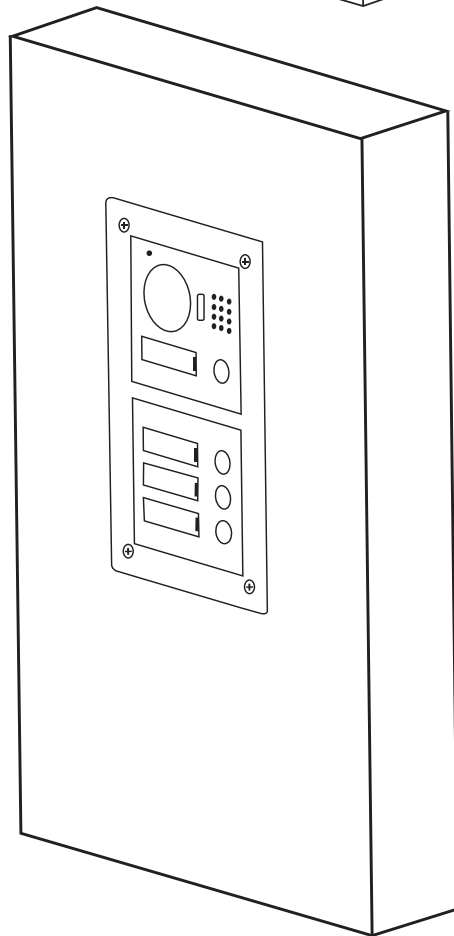
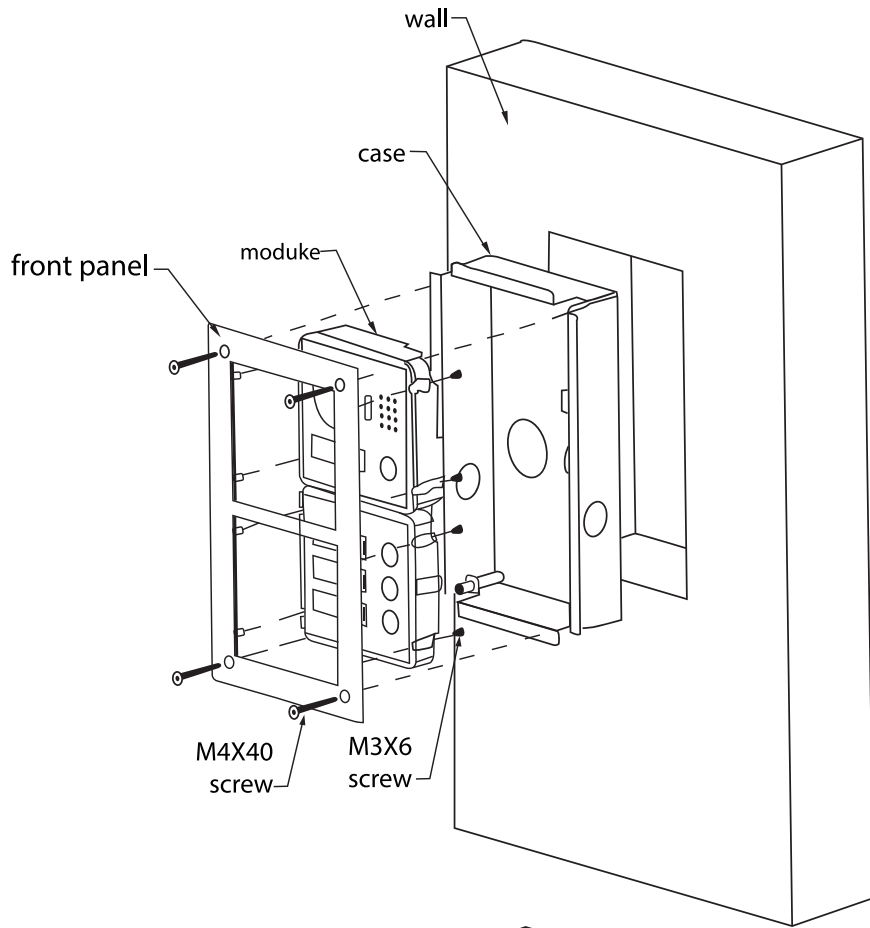

All specifications are subject to change without notice. Copyright © Luxrite Ltd. All rights reserved